

NANO-N

mA Input

Installation

Maintenance

Repair

Manual

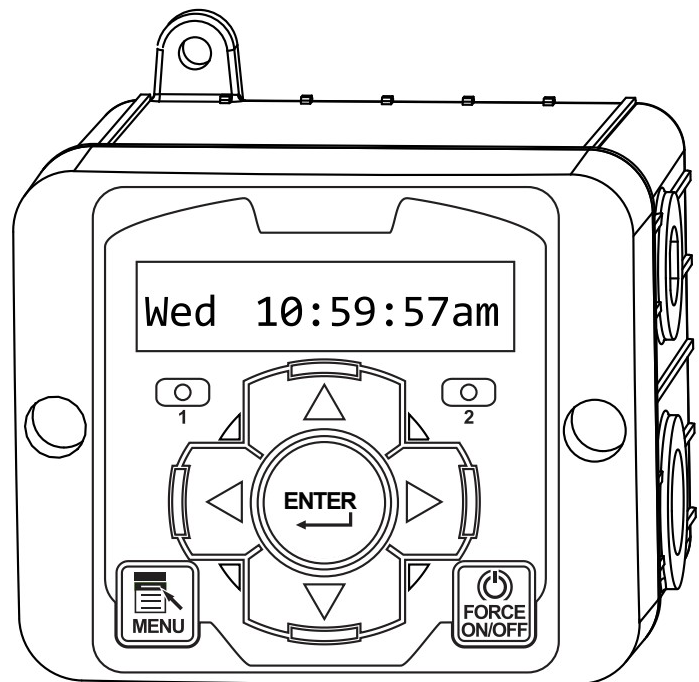

Intertek

Advantage Europe

The European branch of Advantage Controls

Support: info@advantage-eu.com

Website: www.advantage-eu.com

Vorsterweg 26
3980 Tessenderlo-Ham

Belgium

11/2017

Table of Contents

Contents	Page
I. Introduction.....	3
II. Description.....	3
III. Installation	
Electrical Wiring.....	4
Mounting Instructions	4
Relay Cards.....	4
Logic Cards	5
IV. Front Panel Description.....	6
V. System Operation Overview.....	6
Description of Menus.....	6
VI. Maintenance	7
VII. Troubleshooting.....	7
VIII. NanoTron mA Menu Map	8
IX. Warranty & 30 Day Billing Memo Policy	10

I. Introduction

NanoTron microprocessor based controllers are designed to provide a wide range of control functions. The controller is programmed through a front panel keypad and can be configured to provide a customized control system for your application. Your particular unit's functions can be determined by comparing the units model number to the Model Numbering table listed below.

Model Numbering

NANO-N units have several base system control functions and unit optional features. Your unit may be supplied with one or more of the features described in this manual. To determine what features apply to your unit check the model number label located on the controller enclosure.

Base Control Function

N - mA Input, mA Output,
and 1 Feed Timer

Whole Unit Optional Features

A - Conduit Connections

A3 - Conduit with CE

E - Flow Switch

K - Prewired output cable

W - Larger enclosure

Y - ETL Listing / Approvals

II. Description

NANO-N units are designed to display a mA input and transmit a mA and/or pulse output. It also can provide an automated control of chemical feeds and other external devices via two control relay outputs.

The pulse output can pace a metering pump or convert a mA flow rate into contact style water meter pulses (like used in a MegaTron). Follow the steps below to program the Pulse Out based on the mA range of the flow device using an example of 500 gpm as the max 20mA signal:

1. In the Configure menu set the Pulse output to ON
2. In the Configure menu define what the flow rate from the flow device is for:
 - a. 4mA as 000.0 (this is the flow rate of the device with no flow)
 - b. 20mA as 0500.0 (this is the flow rate of the device at maximum)
3. In the Pulse Output menu define:
 - a. LoRate as 000.0 (this is the gpm flow rate at 4mA)
 - b. HiRate as 0500.0 (this is the gpm flow rate at 20mA)
 - c. HiMax as 0100 (this is the number of pulses out per minute it will produce at a 20mA)
4. Go to the water meter input menu of the controller you are sending the pulse output to and define the input as 5 gallons per contact.

III. Installation

Mounting Instructions

Select a mounting location that provides the operator easy access to the unit and a clear view of the controls through the cover of the controller. The location should be convenient to grounded electrical connections, the needed sample line plumbing and is on a stable vertical surface.

⚠ WARNING: Avoid locations that expose the controller to direct sunlight, vapors, vibration, liquid spills or extreme temperatures; less than 0°F (-17.8°C) or greater than 120°F (50°C). EMI (electromagnetic interference) from radio transmissions and electric motors can also cause damage or interference and should be avoided.

Electrical Wiring

The controller has an internal regulated power supply that will operate in the range of approximately 100 to 240 VAC on the incoming wiring. Output relay(s) are protected with a replaceable fuse. Relay output voltage will equal the incoming line voltage.

Prewired units are supplied with a 16 AWG cable with a 3-wire grounded USA 120 volt plug for incoming power and 18 AWG 3-wire grounded receptacle cords for all control relay outputs. Conduit units are supplied with liquid tights and adaptors for easy hard wiring to supplied connector.

NOTE: Liquid tight fittings and some labeled signal leads are provided for signal (low voltage) connections, such as water meter inputs.

⚠ WARNINGS

1. The controller should be connected to its own isolated circuit breaker, and for best results, the ground should be a true earth ground, not shared. Wiring must be done according to all applicable local codes.
2. Power (line voltage) must be disconnected while making any connections. If power is supplied to the unit, line voltage will be present on the relay cards.
3. Low voltage signal wires (probes, flow switch, water meter, etc.) should never be run in conduit with high voltage wires.
4. Hall effect meters that require +12 VDC must use an external power supply (TFS-PWR).

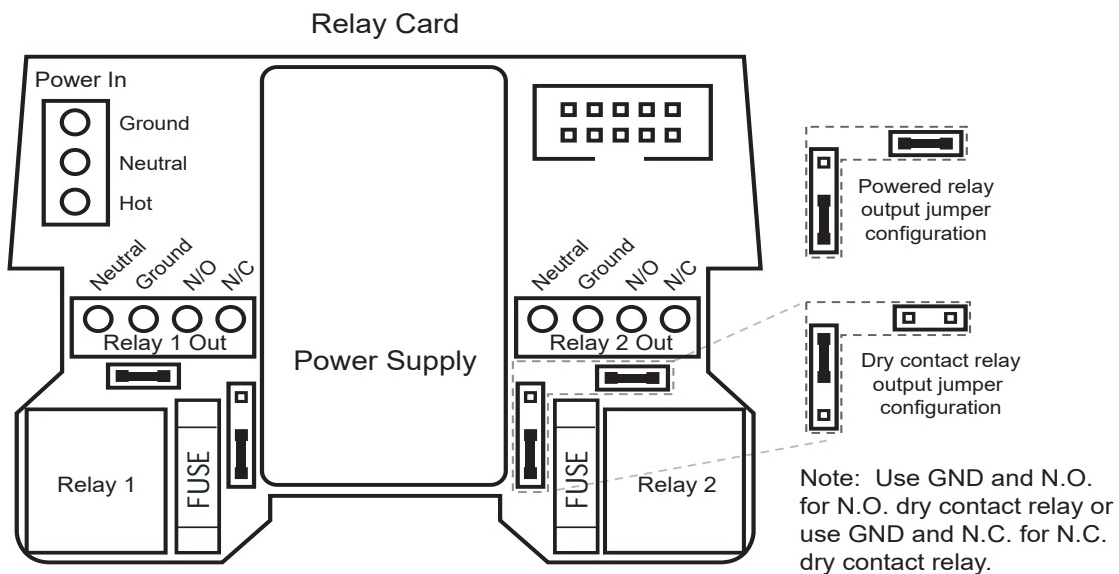

Relay Card for W Option

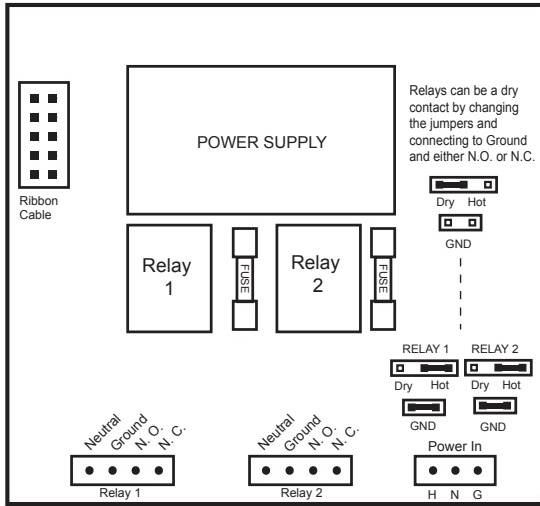

Switch #	Position	Function
1	OFF	Backlight off; flashes on w/ alarm
1	ON	Backlight on; flashes off w/ alarm
2	OFF	Normal Operation
2	ON	“Burn-in” Mode
3	OFF	Normal Operation
3	ON	Resets to factory defaults

Note: Relay 1 is for mA reading control. Relay 2 is for Single Timer

NanoTron-N Logic Card

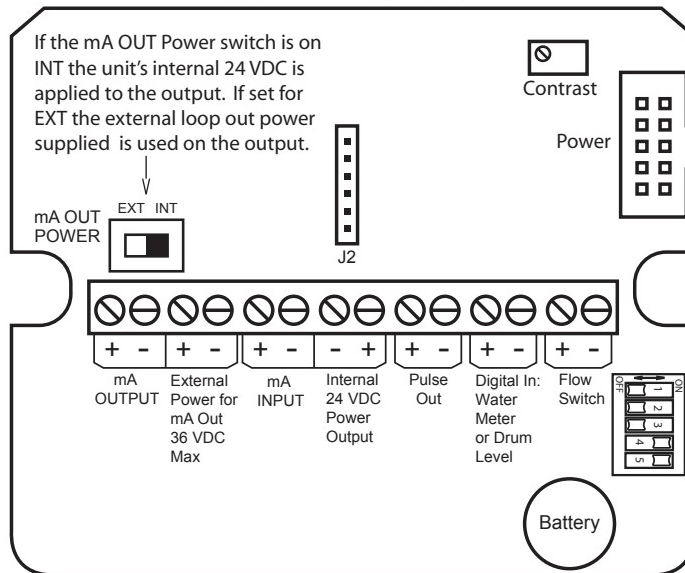

Wiring for two-wire input sensors that need 12-24 VDC on the loop.

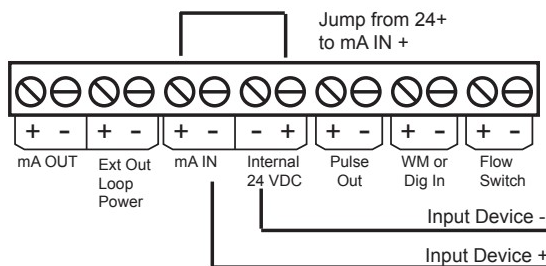

Wiring for four-wire input sensors that need 12-24 VDC on power input.

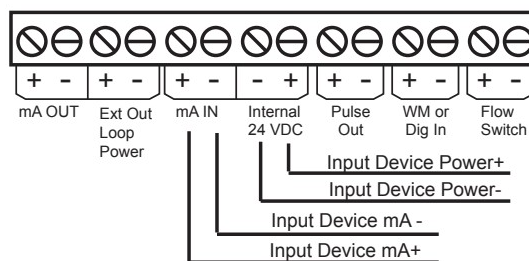

IV. Front Panel Description

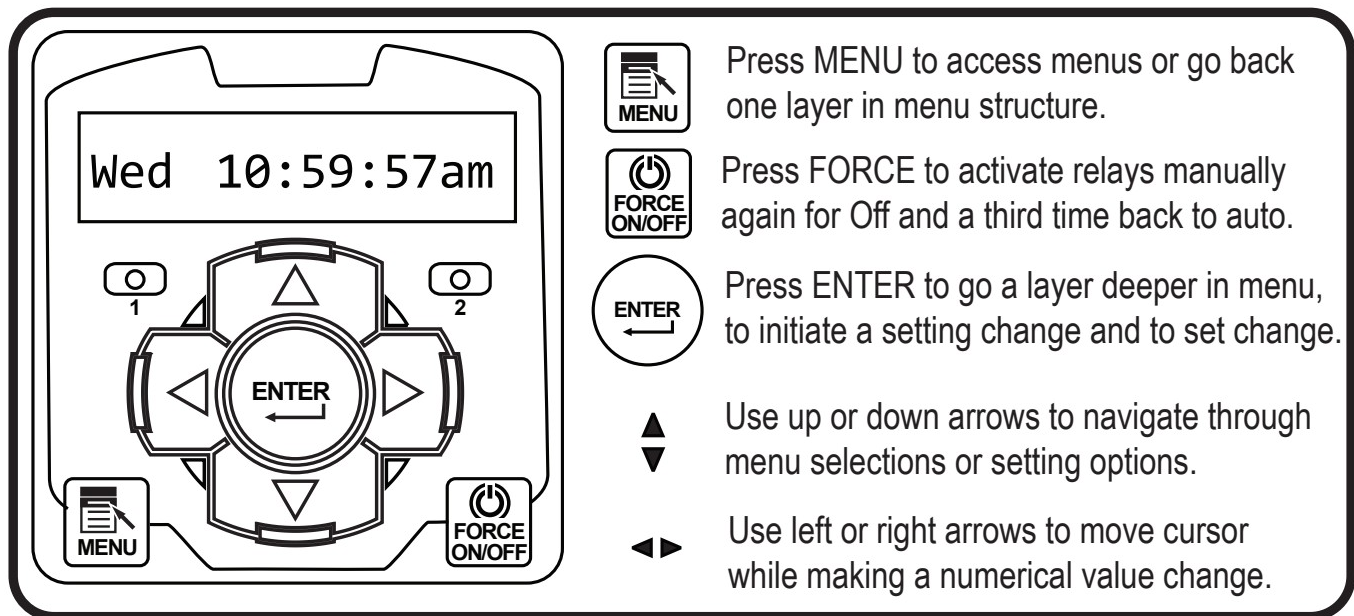

V. System Operation Overview

Description of Menus

NanoTron controllers have three modes of operation, Run, Menu and Force. All menus are circular. Pressing the DOWN key will display the next line of information on the display.

Run - This mode is for normal operation. The control relays will only be automatically active in this mode. In the Run mode, the display will read system values. If an alarm is present, the display flashes with the alarm status.

The Run menu will display values such as day, time, date and other values depending upon the features present on the unit. The unit will automatically return to the Run mode if no keys are pressed for three minutes.

Menu - This mode is used to make adjustments to settings and readings on the controller. To access the Menu mode from the run screen, press the Menu key. Use the up or down arrow to scroll through the various menus. When you want to access a specific menu, press the Enter key. Once you have entered a sub-menu you will be able to step through that menu's options with the up or down arrow key.

Force - Relays may be forced on or off for a user defined amount of time. Press the Force key to force relays on for the time configured in the Menu's force sub-menu. Press it a second time to force them off for the same amount of time. Press a third time to go back to automatic Run mode. Unit returns to the Run mode automatically when the force time has elapsed.

VI. Maintenance

The only required maintenance for normal uninterrupted operation of your controller is cleaning of the electrode(s). After initial start up, it is a good idea to clean the electrode frequently until a schedule based on need has been developed. Since each application is unique, it is difficult to estimate the required frequency of cleaning. The first cleaning should take place after about one week of the system being on line.

To determine the required cleaning frequency, record the reading on the controller before the electrode is removed for cleaning. After cleaning, record the new reading. If a change is observed in the two readings, the electrode was dirty. The more significant the change, the dirtier the electrode. If no change occurs, cleaning needs to be done less often.

VII. Troubleshooting

The Advantage NanoTron controller is designed for many years of trouble free operation. Should a problem occur, refer to the following chart to help identify the problem. If replacement is required, follow the procedures listed in the Warranty and Factory Service portion of this manual.

SYMPTOM	POSSIBLE CAUSE	SOLUTION
False reading.....	Bad or dirty electrode	Clean, as needed
	Out of calibration	Calibrate unit
Will not calibrate	Dirty electrode	Clean electrode
	Faulty electrode	Replace electrode if needed
	Faulty wiring to electrode	Replace wiring if needed
No system power.....	Check power source	Plug into different receptacle
	Check fuse	Replace as needed
	Check connections	Make sure ribbon cables are secure
	Check wiring	Repair as needed
Pulse timer not activating	Check external device	Repair/replace as needed
	No flow	Check sample line for clogged pipes or strainers
Outputs not energized	Check fuse	Replace as needed

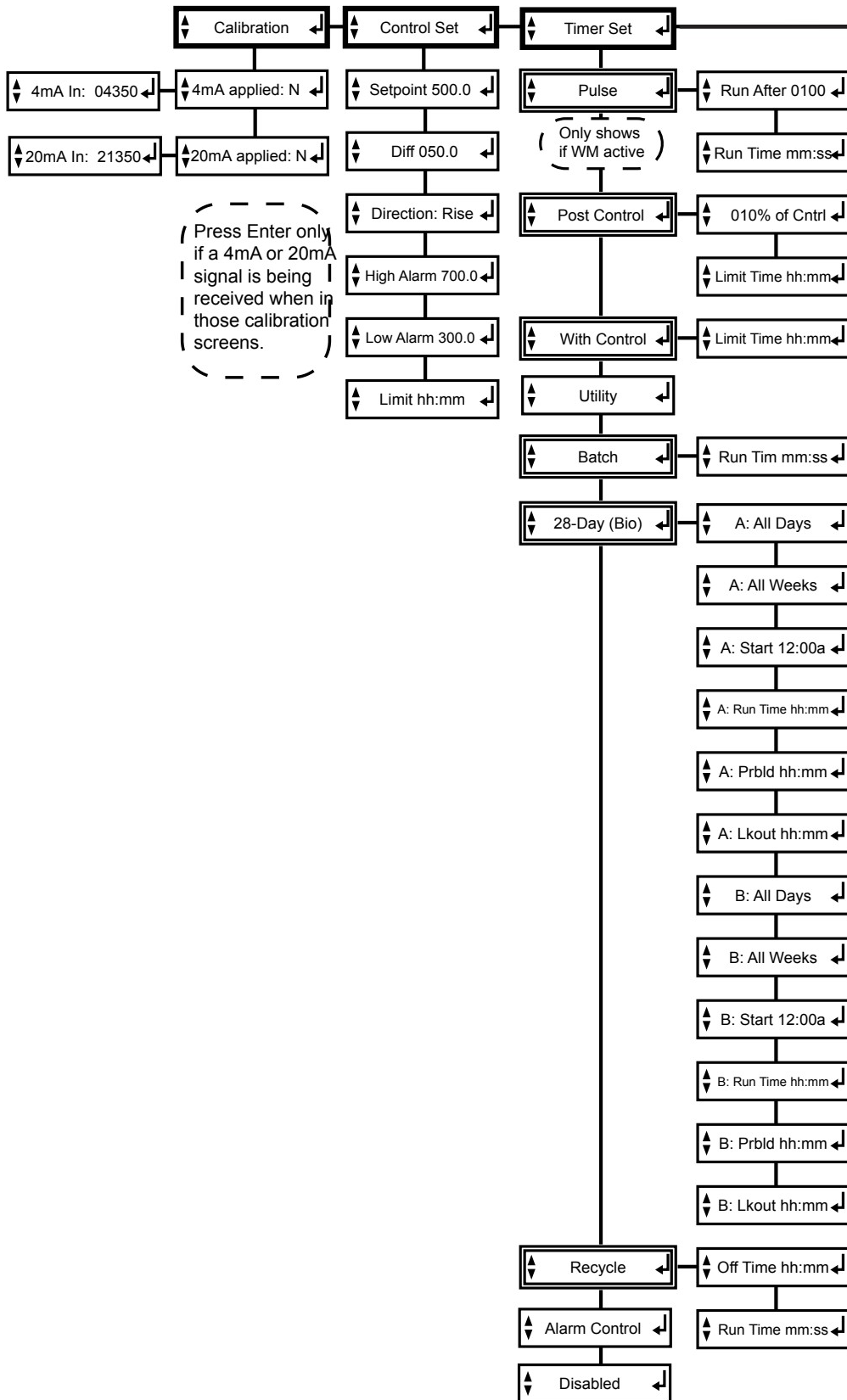

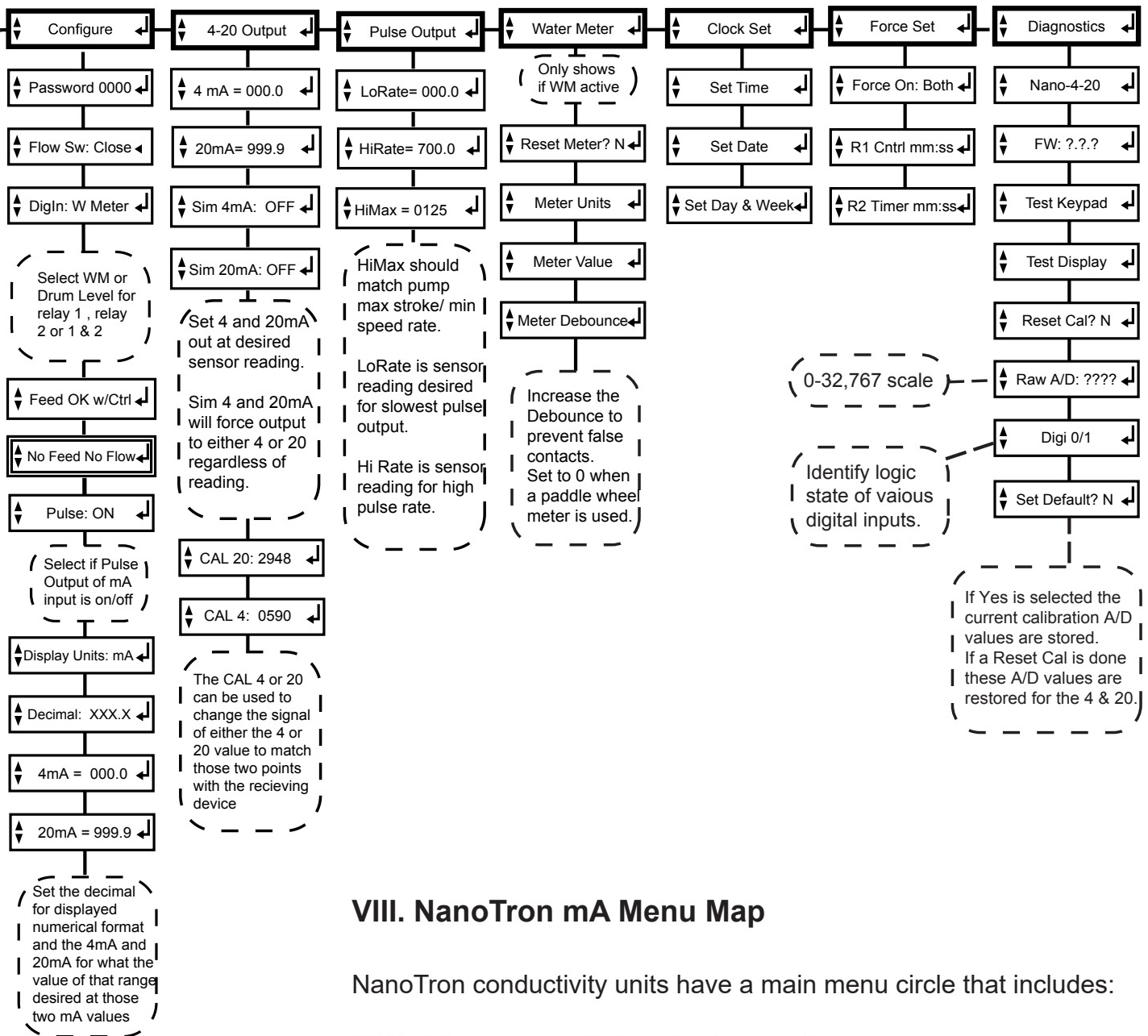

VIII. NanoTron mA Menu Map

NanoTron conductivity units have a main menu circle that includes:

- | | |
|---------------------|--|
| Calibration | - Calibrating the reading |
| Control Set | - Setting the set point, sample method and alarms |
| Timer Set | - Select the timer type and run values |
| Configure | - Password, flow switch direction, units of measure and more |
| 4-20 Output | - Calibrate and set the range of the mA output |
| Pulse Output | - Set the range and speed of the pulse output |
| Water Meter | - Reset totalizer and setting contact value |
| Clock Set | - Set time, date and week |
| Force Set | - Set the force on time for manual relay activations |
| Diagnostics | - Tests and calibration reset |

IX. Manufacturer's Product Warranty

Advantage Controls warrants units of its manufacture to be free of defects in material or workmanship. Liability under this policy extends for 24 months from date of installation. Liability is limited to repair or replacement of any failed equipment or part proven defective in material or workmanship upon manufacturer's examination. Removal and installation costs are not included under this warranty. Manufacturer's liability shall never exceed the selling price of equipment or part in question.

Advantage disclaims all liability for damage caused by its products by improper installation, maintenance, use or attempts to operate products beyond their intended functionality, intentionally or otherwise, or any unauthorized repair. Advantage is not responsible for damages, injuries or expense incurred through the use of its products.

The above warranty is in lieu of other warranties, either expressed or implied. No agent of ours is authorized to provide any warranty other than the above.

30 Day Billing Memo Policy

Advantage Controls maintains a unique factory exchange program to ensure uninterrupted service with minimum downtime. If your unit malfunctions, call 1-800-743-7431, and provide our technician with Model and Serial Number information. If we are unable to diagnose and solve your problem over the phone, a fully warranted replacement unit will be shipped, usually within 48 hours, on a 30 Day Billing Memo.

This service requires a purchase order and the replacement unit is billed to your regular account for payment.

The replacement unit will be billed at current list price for that model less any applicable resale discount. Upon return of your old unit, credit will be issued to your account if the unit is in warranty. If the unit is out of warranty or the damage not covered, a partial credit will be applied based upon a prorated replacement price schedule dependent on the age of the unit. Any exchange covers only the controller or pump. Electrodes, liquid end components and other external accessories are not included.

FCC Warning

This equipment generates and uses radio frequency energy and if not installed and used properly, that is, in strict accordance with the manufacturer's instruction, may cause interference to radio communications. It has been type tested and found to comply with the limits for a class A computing device pursuant to subpart J of part 15 of FCC Rules, which are designed to provide reasonable protection against such interference when operated in a commercial or industrial environment. Operation of this equipment in a residential area is likely to cause interference in which case the user, at his own expense, will be required to take whatever measures necessary to correct the interference.

Get the Advantage in Water Treatment Equipment

Advantage Controls can give you the *Advantage* in products, knowledge and support on all of your water treatment equipment needs.

- Cooling Tower Controllers
- Boiler Blow Down Controllers
- Blow Down Valve Packages
- Solenoid Valves
- Water Meters
- Chemical Metering Pumps
- Corrosion Coupon Racks
- Chemical Solution Tanks
- Solid Feed Systems
- Feed Timers
- Filter Equipment
- Glycol Feed Systems
- Pre Fabricated Systems

