



Europe
Advantage

Accessories



INDEX

Accessories

- ***Cooling Towers***

- Corrosion Coupon Racks and Loop Guards
- Bleed Valves
- Flow Switches
- Glycol Feeders
- Handheld Testers
- Simulators for Calibration
- Filling Controllers
- 24 VDC Power Supply
- Water Meters
- Signal Splitters

- ***Boilers***

- Boiler Valve Stand
- Boiler Blowdown Valve Packages
- Sample Coolers

- ***Prefabricated Systems***

- ***General***

- Sensors
- AFS Automatic Flushing Stations

Corrosion Coupon Racks and Loop Guards

- Build to ASTM Specs
- Corrosion resistant
- Rotameter and control valves
- Standard or custom design
- Quick Release Holder
- Integrated in our prefab controller panels
- Closed Loop Corrosion Monitoring and Feed panels

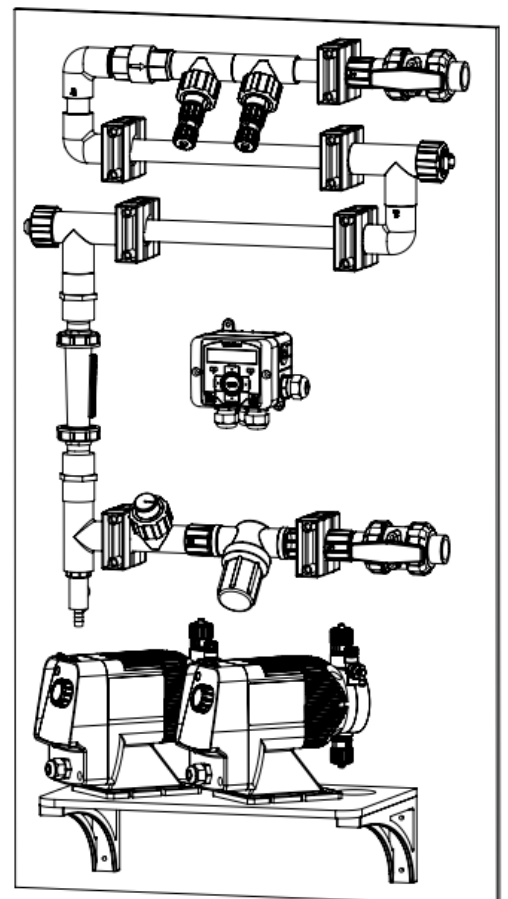
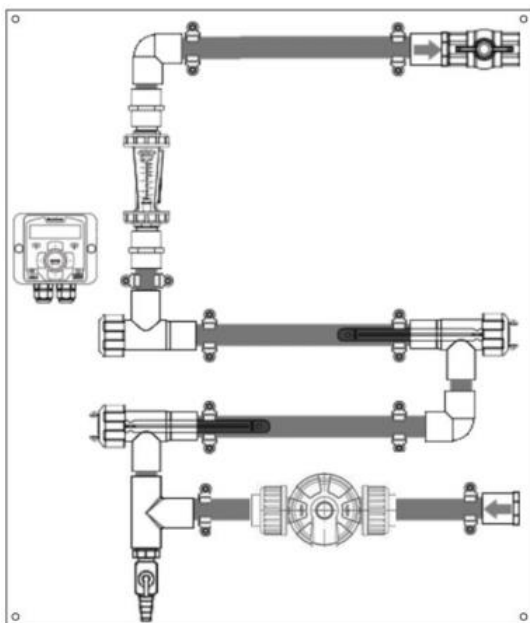

Bleed Valves

- Motorized ball valve
- Stainless Steel, PTFE, EPDM
- 85-265VAC Working voltage
- Normally closed



Flow Switches

FS-OC

Cap and float style flow switch

- With 3/4" PVC Tee, 10 Bar @ 24°C
- Voltage (max): 30 VDC
- Current (max): 0,2 A
- Power (max): 6 W



Flow-75-10AFS

Flow indicator 0-35 L/min with adjustable flow switch

- 3/4" MNPT, 25,4 mm long
- PVC assembly 6,9 Bar @ 50°C
- Voltage (max): 30 VDC
- Current (max): 0.2 A
- Power (max): 6 W



Glycol Feeders

- For closed loop systems
- With NanoTron or MegaTron XS
- Digitally displayed pressure
- Simple setpoint control
- High flow feed pump
- Preplumbed and prewired
- Powdercoated steel frame



Handheld Testers

Hantron

Handheld Conductivity Meter

- 1 μ S/cm Resolution
- Stores 20 readings
- Easy to use and very economical



Multimeter by Pyxis

- PTSA, pH, ORP, Cond, Temp and Total Chlorine measurement options



Simulators for Calibration

HT-SIM-MOP

Handheld signal simulator

- Simulates pH, ORP and powered mA signals
- Three different levels for each signal type



Filling Controllers

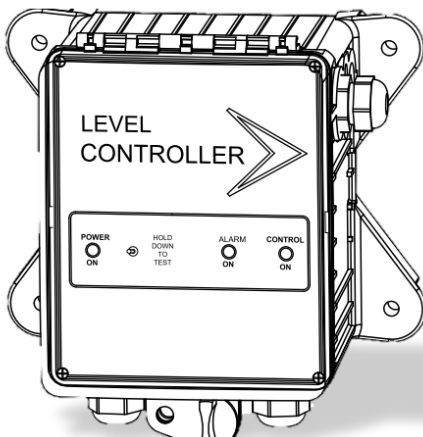

FILL Controller

- Possible together with level switches
- Controller that operates a relay for filling between a low and high level
- NEMA 4X Type Enclosure

24 VDC Power Supply

PSDC-24-Q

24 VDC Power Supply for

- 4-20 mA Sensors
- Valves
- General use



Water Meters

AWM Series



- Multi-Jet design
- Brass body
- Low cost
- Pulse output option available

Signal Splitters

AWM-SS-4 Series

Split a single water meter signal to be isolated sent to three different devices

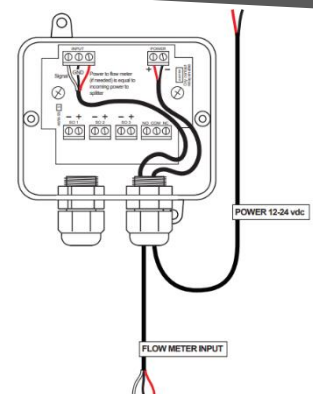

Solid Feed Systems

SFS Series

Solid Chemical Dissolving System

- Universal bowl: accepts wide range of round 1 gallon container chemicals
- Molded tank solution
- Pressure regulator
- Level controller
- Removable Floats
- LED Indicators
- Pressure guage
- Non-Electrical option



Brominators

Biocide tablet feeder

See-through body design

Use chlorine tablets or Bromine pucks

Safe chemical feeding system for:

- Cooling tower biocide
- Condensers
- Re-circulation loops
- Hexametaphosphate Feeder
- Irrigation system and swimming pools



Boiler Valve Stand

- Simplify installation
- Save time & money
- Sample stream options
- Prefab solutions

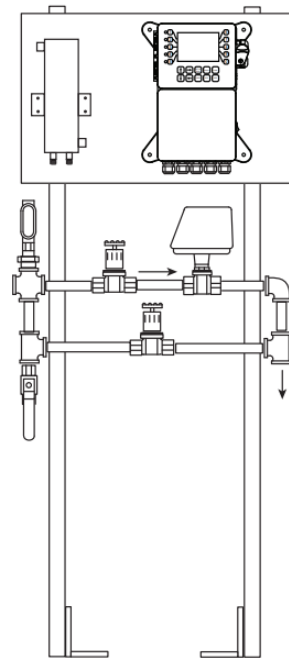

Boiler Blowdown Valve Packages

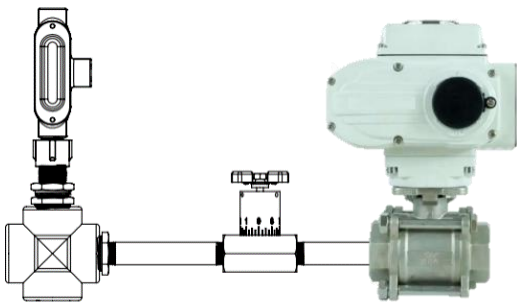

- Selectable with or without plumbing options
- 220 VAC Motorized ball valves for steam

Sample Coolers

LBC-SS Series

- Stainless Steel
- Easy to install with mounting brackets provided



Prefabricated Systems

- Let us do your plumbing
- Several standard and custom pre-fab options
- Saving time and money

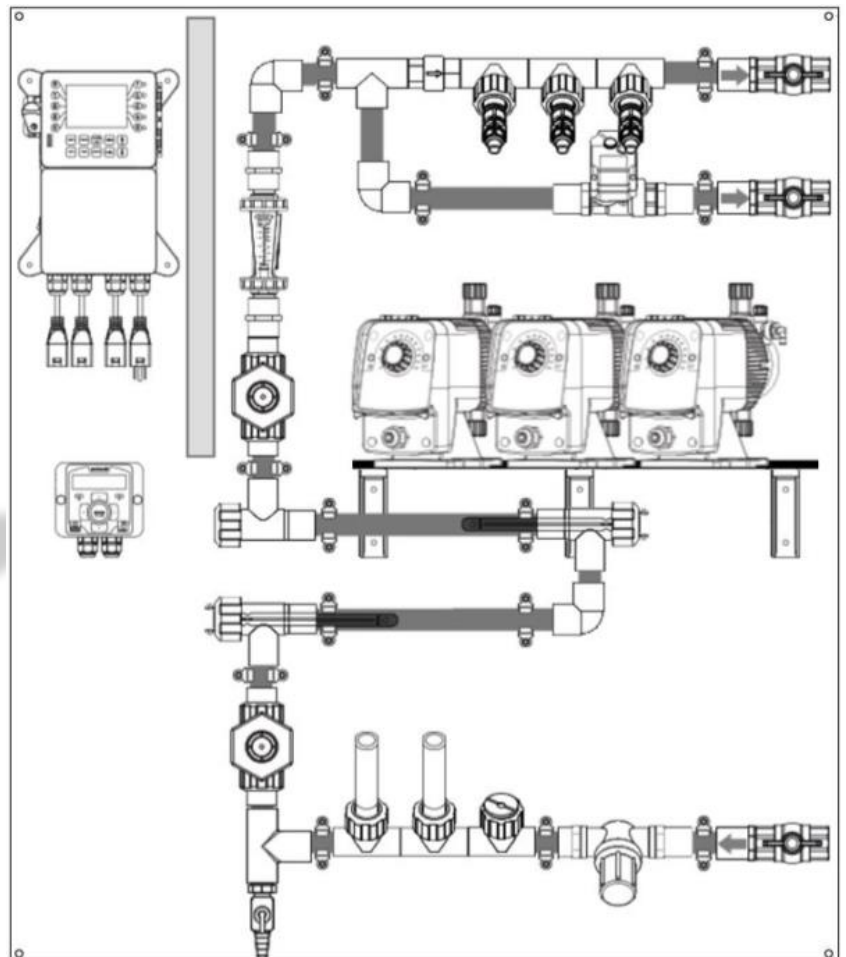
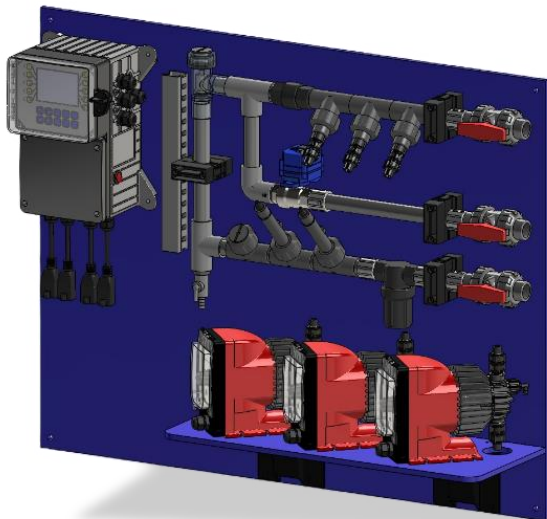

Sensors

- Conductivity
- pH and ORP
- LPR Corrosion
- PTSA
- Tagged Polymer
- Dissolved Oxygen
- Turbidity
- Disinfection (Free Chlorine,..)
- Biofilm / Fouling
- Level (Radar, Ultrasonic, Dry contact)



AFS Automatic Flushing Station

Kill dead legs by flushing water lines periodically

- Easy wall installation
- Lockable enclosure
- 1" Ball Valve
- 28-Day Timer
- Overflow Sensor



Advantage *Europe*



Contact

Yorben Verboven | *European Sales Manager*

+32 470 05 59 89

Verboven.y@advantage-eu.com

Jeroen Wouters | *European Technical Manager*

+32 498 65 75 30

Wouters.j@advantage-eu.com

Visit our website for more info

www.advantage-eu.com

And follow us on LinkedIn

