

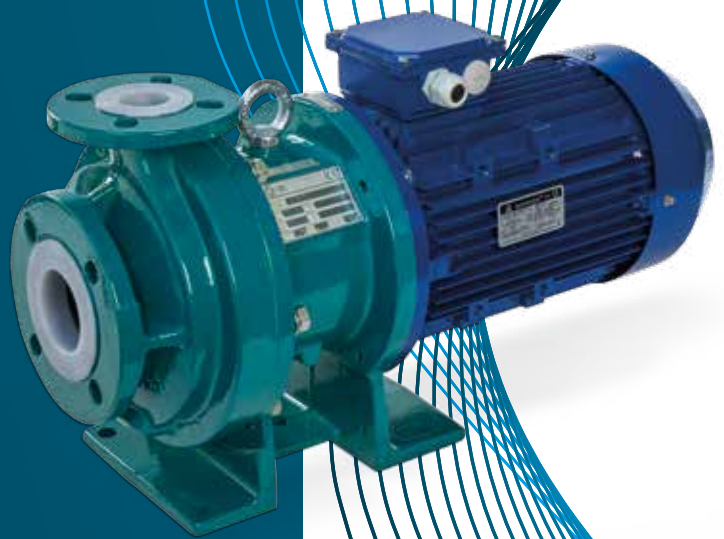

WE  
PUMP  
YOUR  
CHEMICALS



# ETN evo SERIES

LINED MAGNETIC  
DRIVE PUMP

# ETN evo close coupled execution

## Range of applications

- \_ Basic chemical services
- \_ Fine chemical batch services
- \_ Water treatment
- \_ Air treatment
- \_ Loading/unloading tanks
- \_ Washing circuits (C.I.P.)

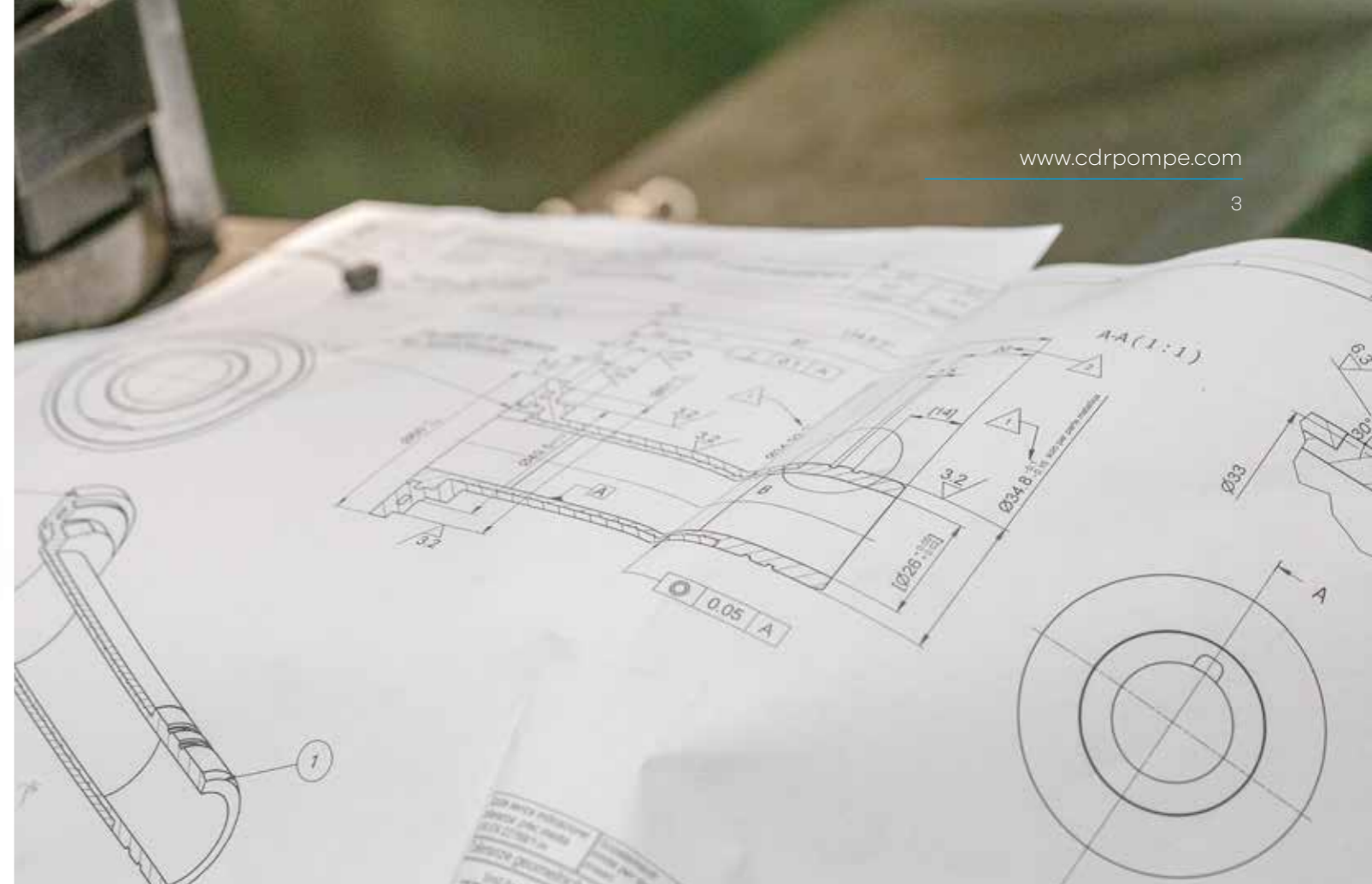

## Mag drive concept

The synchronous drive configuration is based on an outer magnet ring assembly built to magnetically couple with an inner magnet ring assembly. These two magnet rings are locked together by the flux of attracting magnet poles flowing through the containment isolation shell.

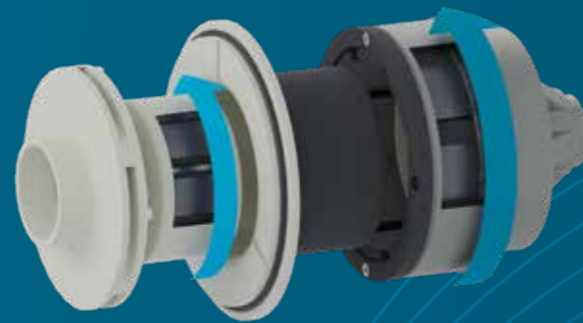

## Design

Simplicity, lightness and economy are the 3 strong points of this pump in cases of occasional handling of chemical products.

## R&D with Fluidodynamic Simulation

Designed with an innovative simulation software, that permits to obtain high hydraulic performances and efficiency levels near to the physical possible values.

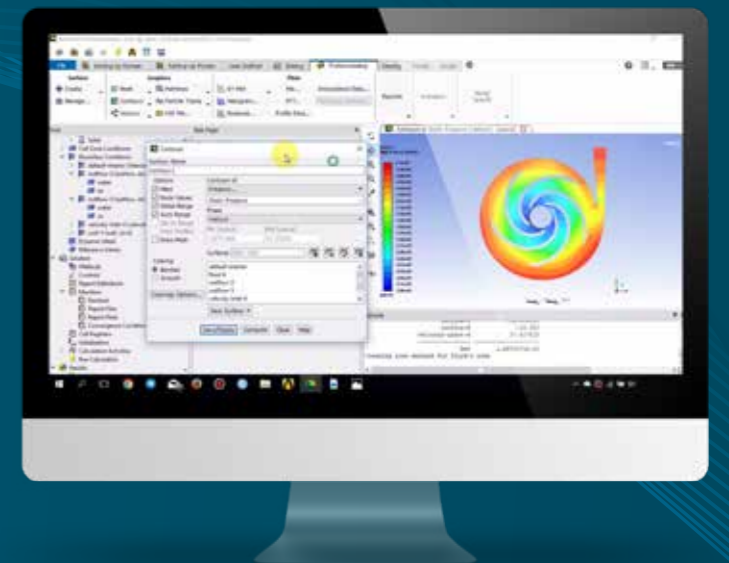

\*All Ansys, Inc. brand, product, logos are registered trademarks or trademarks of Ansys, Inc.

# Diamond coated silicon carbide bushes

## ADVANTAGES

Safety and reliability, features of magnetic drive pumps, are now increased and guaranteed even in the event of accidental dry running, poor lubrication or pumping of low-boiling liquids thanks to the use of RunSafe SiC (diamond coated silicon carbide).

A layer of amorphous material, with a diamond crystalline lattice, is deposited on the sliding surfaces of the SiC bushes using a particular chemical-physical process which also guarantees continuous and solid adhesion of the coating itself.

Critical working conditions in which RSSiC increases the reliability of the pump as well as durability over time:

- \_ Pumping low-boiling liquids
- \_ Work at low flow rates.
- \_ In these conditions the heat generated by the magnetic coupling is not completely dissipated by the process fluid
- \_ Work at high flow rates (above BEP).
- \_ In these conditions, both the risk of cavitation and the risk, due to the low pressure of the delivery fluid, of incorrect heat dissipation in the rear area of the isolation shell simultaneously increase.



## REDUCTION OF FAILURES

The bushes, bearings and shaft in RunSafe SiC guarantee a reduction in the friction coefficient compared to components made of traditional SiC (0.04 .rs of RSSiC instead of 0.4 - 0.7 .rs of SiC) while still maintaining high corrosion resistance.

The reduced friction coefficient (about 80%) of the bushes results in a decrease in the heat generated in critical running conditions (dry running or poor lubrication), thus preventing the classic damage attributable to machine downtime.

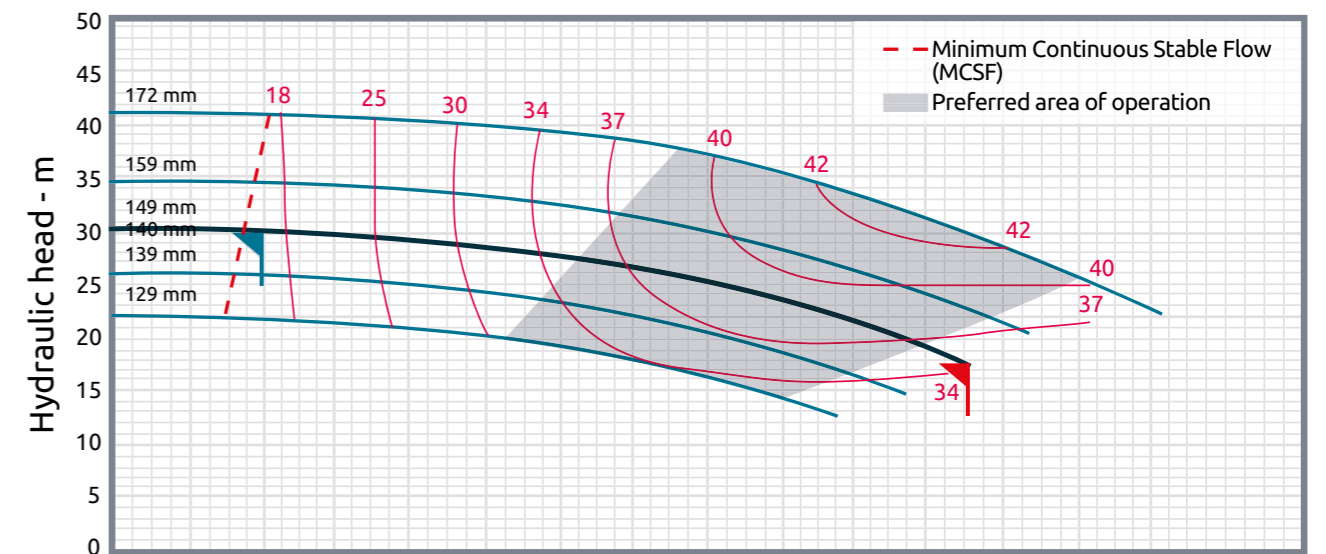

## ETN EVO Series Main features and 3d view

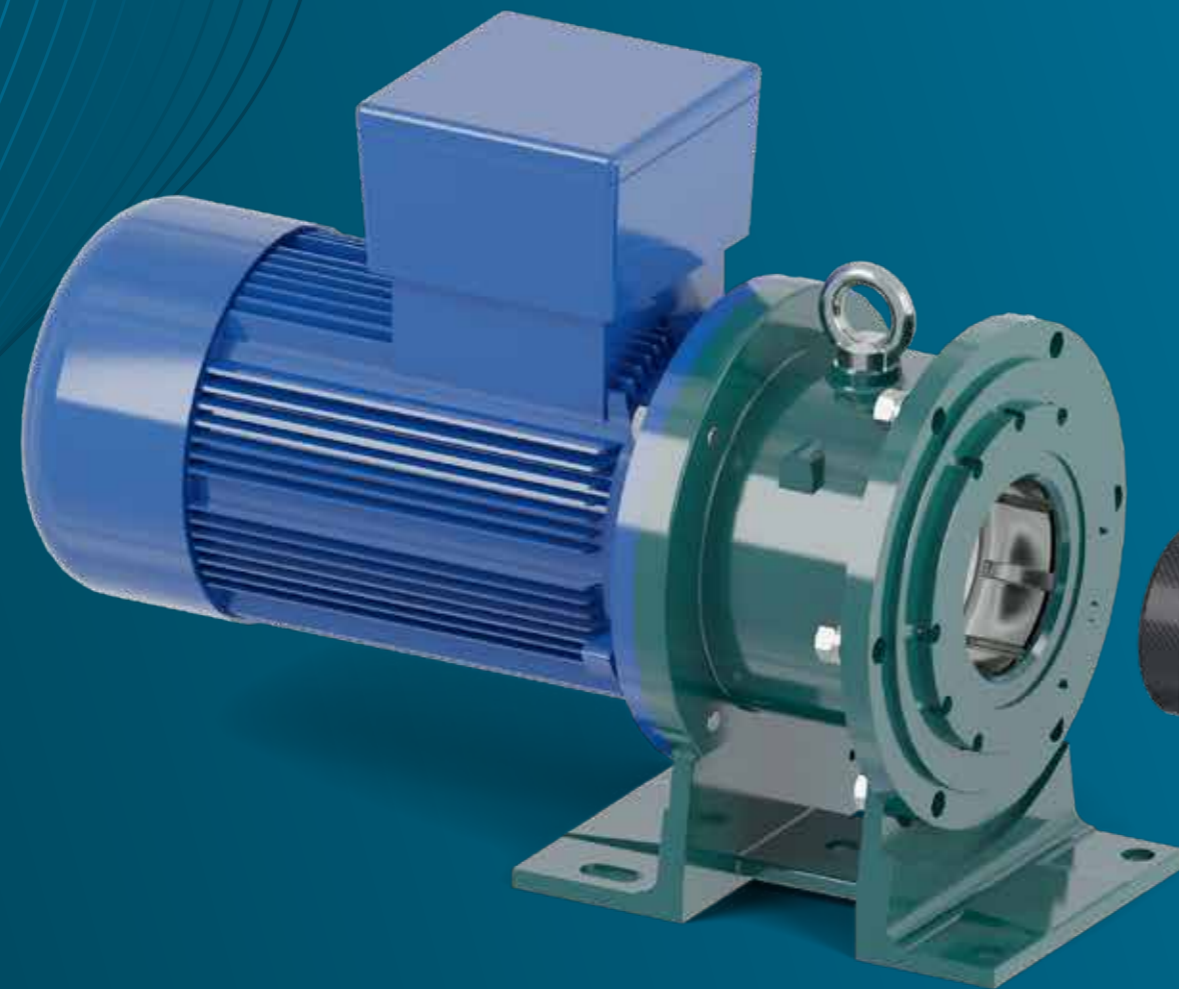

### 01. Isolation shell

Available in ETFE with external polycarbonate reinforcement or in PP. The new design with flushing channels in the shaft housing area ensures correct circulation of liquid between the isolation shell area and the volute pump through the shaft flushing channels.

### 02. Impeller

The one-piece construction of the impeller and Internal magnet simplifies assembly as well as minimizing the risk of seepage.

The presence of counter-blades drastically reduces axial and radial thrust, ensuring longer life of the bushes and shaft.

### 03. Pump shaft and bushes

**New shaft and suction cover:** the new design guarantees better lubrication of the bushes and circulation of the liquid between the volute and the isolation shell.

### 04. Casing

A ductile cast iron body internally lined in ETFE or in PP guarantees excellent resistance to chemical corrosion and mechanical resistance for the connection to the piping.



# Performance Curves

## 50 Hz

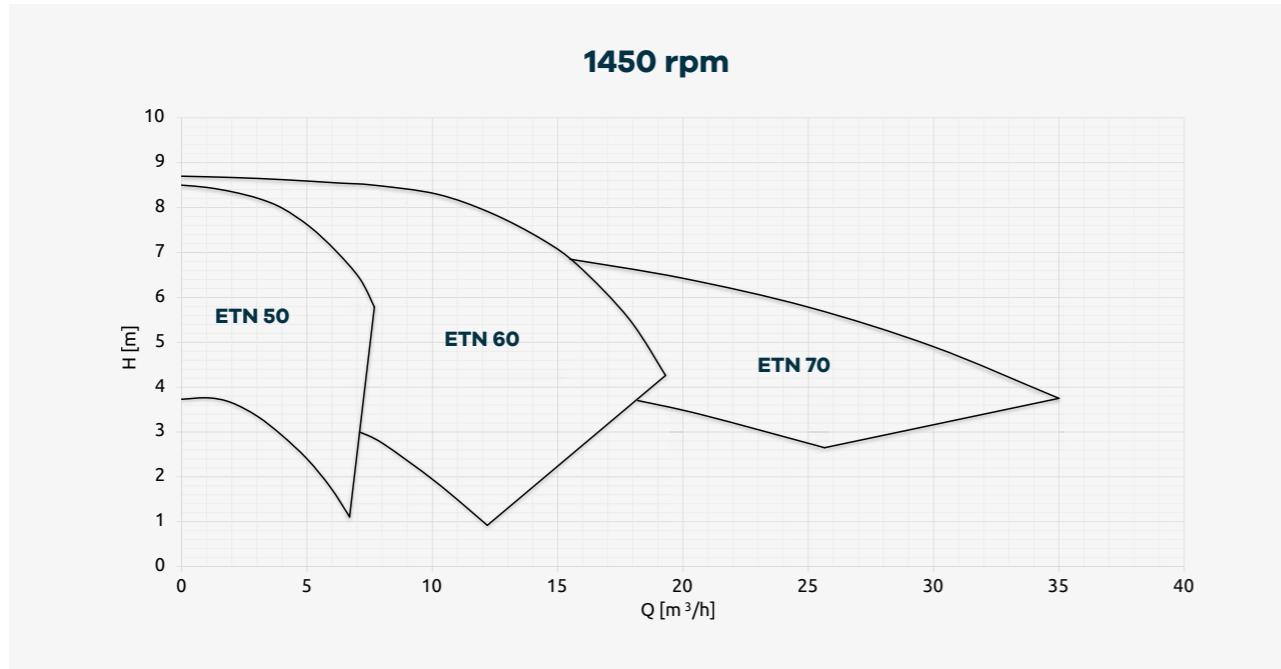

## 60 Hz

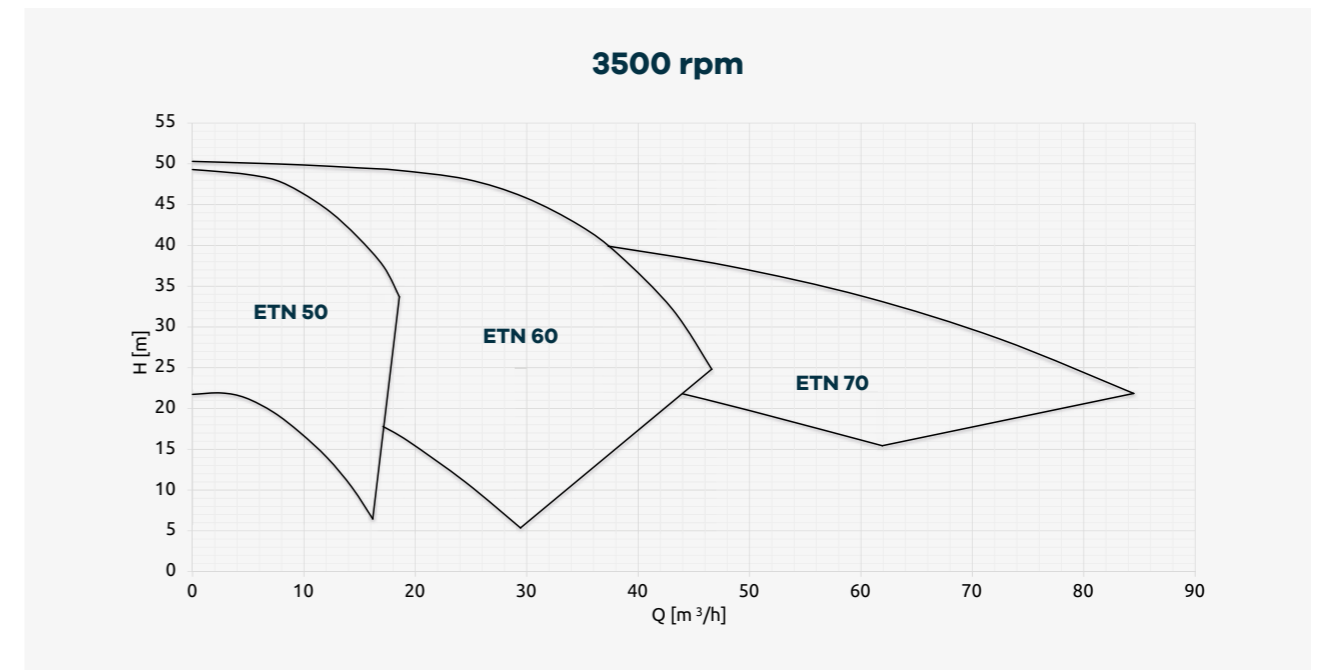
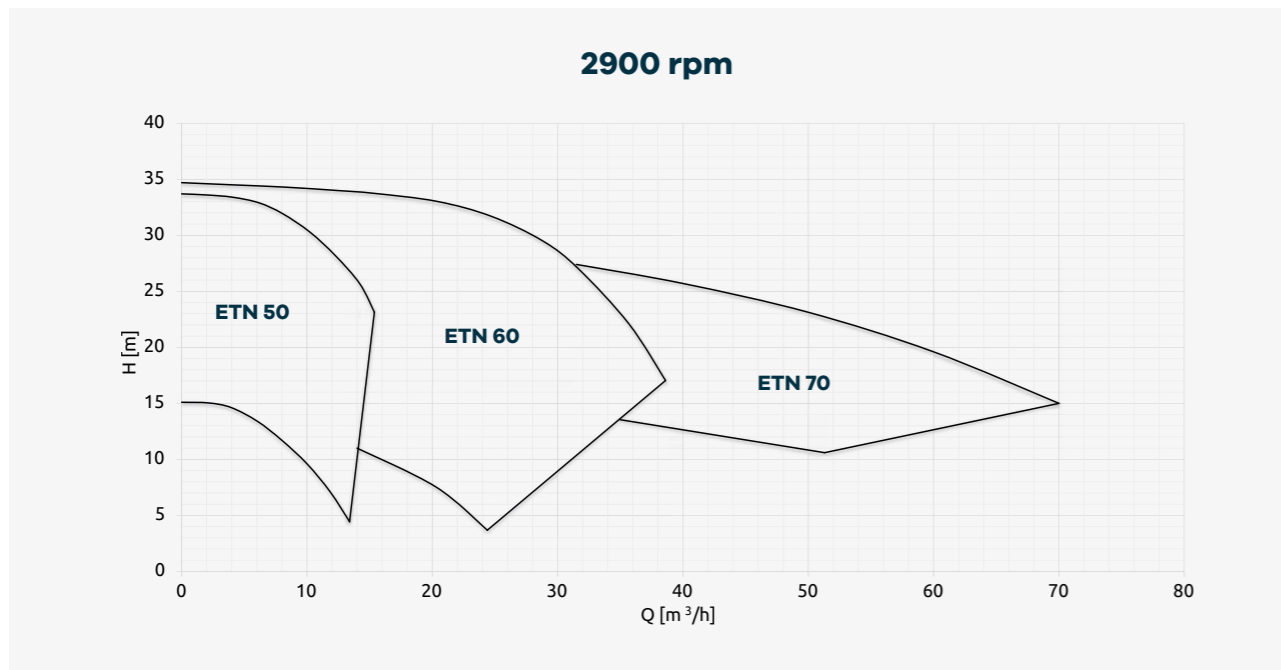
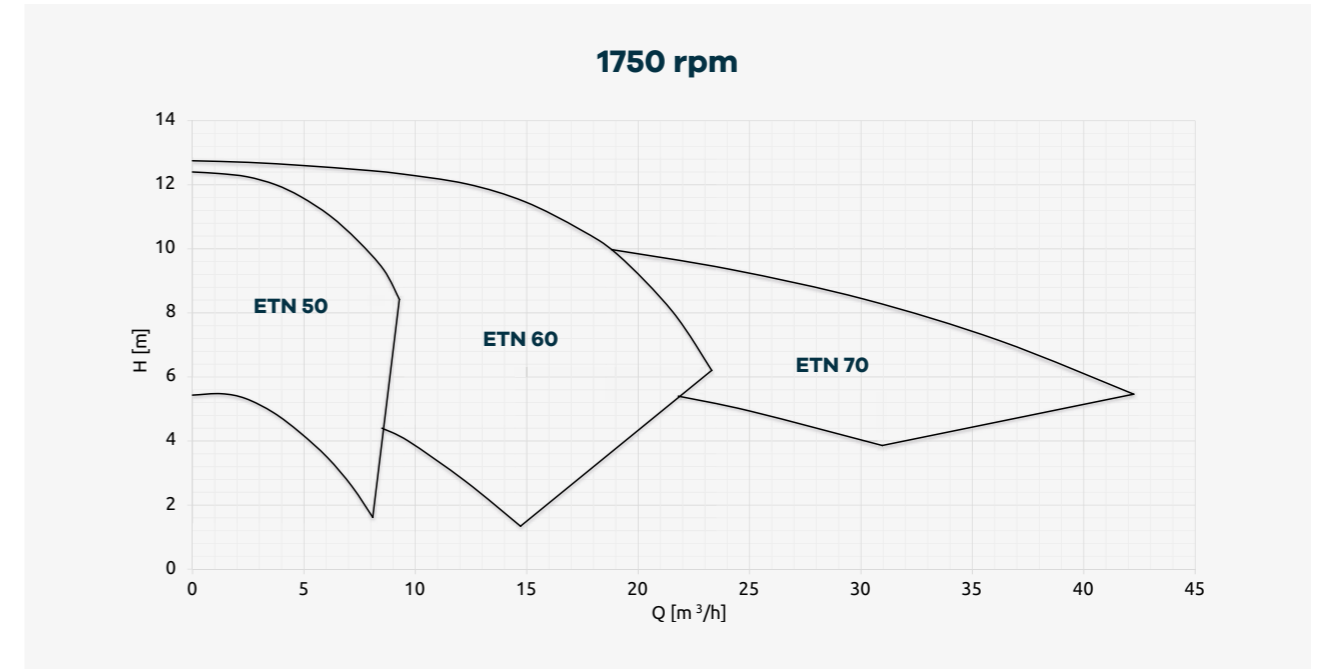

Not binding data refers to water at room temperature.  
For specific performance curve contact CDR Pompe S.R.L.

# ETN evo

## Section drawings

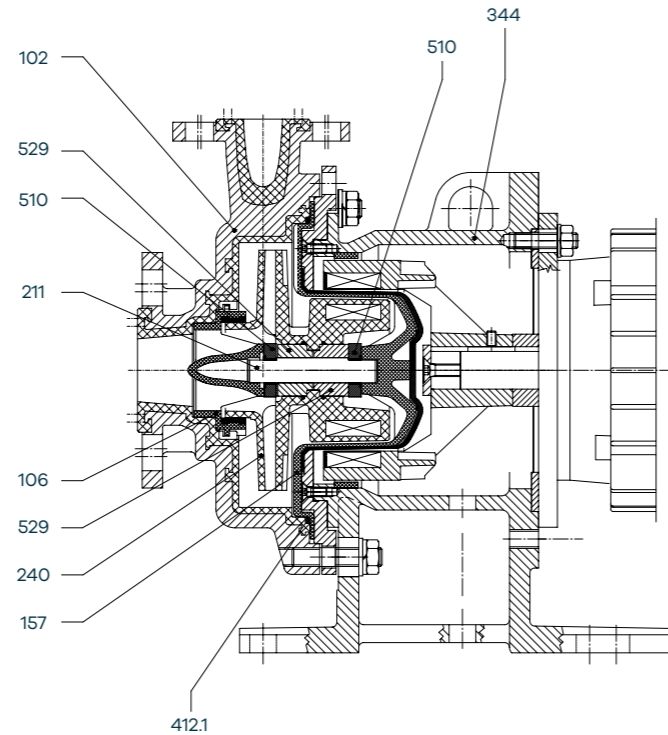

### Technical specifications

- Design**  
EN 22858; sub - ISO 2858
- Performance at 2900 rpm**  
Q max = 60 m<sup>3</sup>/h  
H max = 34 mcl
- Motors**  
0,75 kW (motor size 80)  
7,5 kW (motor size 112)
- Allowable temperatures**  
PP-GF: -10°C > +60°C  
CFR-ETFE: -15°C > +120°C
- Allowable pressures**  
PP: from 6 bar (20°C) to 4 bar (60°C)  
ETFE: from 6 bar (20°C) to 4 bar (95°C)  
CFR-ETFE: from 10 bar (20°C) to 6 bar (120°C)
- Suction/Delivery**  
ETN evo 50: DN40/DN25  
ETN evo 60 : DN65/DN40  
ETN evo 70: DN80/DN50
- Flanges**  
UNI 1092-2 / ISO 7005-2 PN 16, type B  
slotted ASME /ANSI class 150
- Viscosity**  
min: 0,5 cSt  
max: 150 cSt
- Allowable solids**  
Max concentration: 2% by weight  
Max size: 0.10 mm

### Internal components

DIN	Components	Materials
102	Casing	PP lined / ETFE lined
106	Suction Body	ETFE+CF
157	Isolation shell	ETFE+PC+PP
211	Pump shaft	SiC / Al2O3 / RunSafeSiC
240	Impeller	PP / ETFE
344	Lantern	GS400
412.1	O-Ring (Casing)	EPDM / FPM / FPM-FEP
510	Thrust bearings	SiC / Al2O3 /RunSafeSiC
529	Rotating Bushes	SiC / PTFE-Al2O3 Graphite / RunSafeSiC
856	Magnetic Core External	GS400+Ryton
510	Thrust bearings	SiC / Al2O3
529	Rotating bushes	SiC / PTFE-Carbon / Graphite
856	N.M.E.	GS400+Ryton
912	Drainage cap	PTFE
723.1	Suction flange	PP-Steel / AISI 304
723.2	Delivery flange	PP-Steel / AISI 304
740.1	Suction joint	PP / ETFE-AISI 304
740.2	Discharge joint	PP / ETFE-AISI 304



# ETN evo

## Overall dimensions

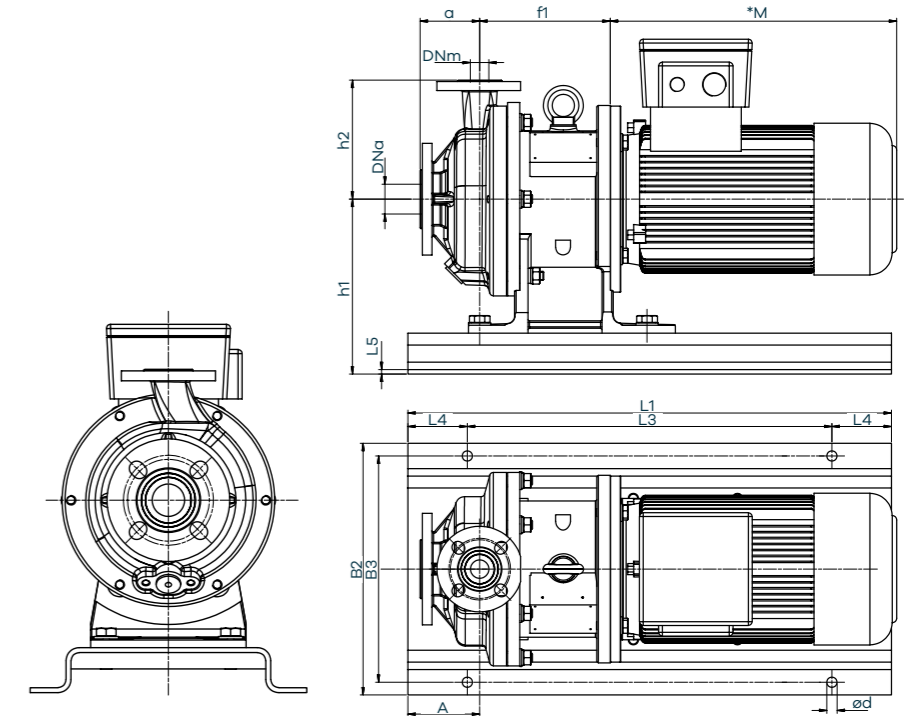
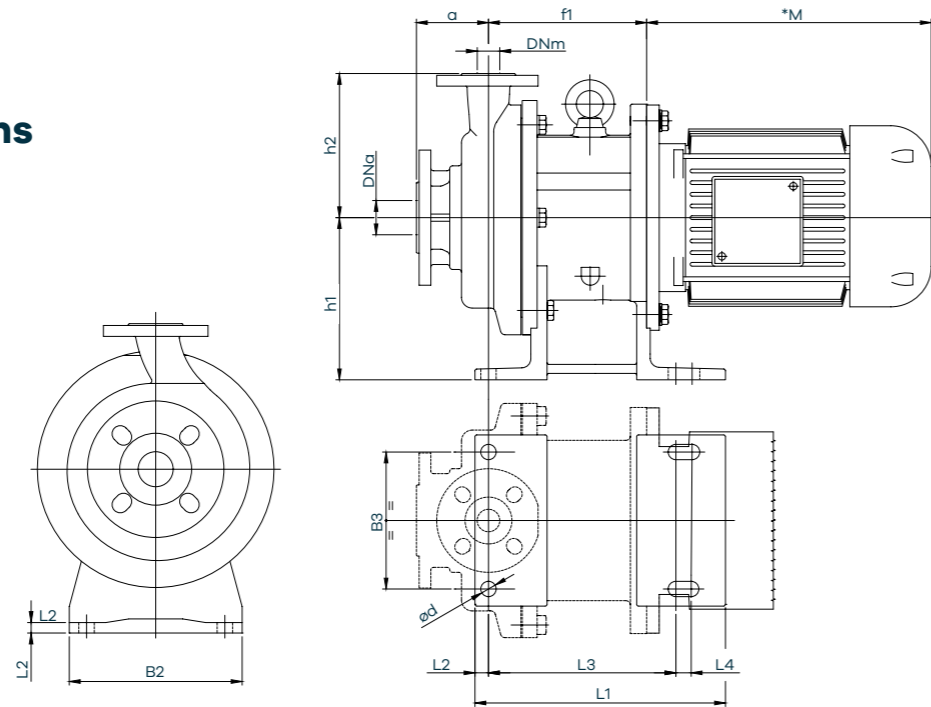

### Pump dimensions

Model	ETN EVO 50 PP / ETFE	ETN EVO 60 PP / ETFE	ETN EVO 70 PP / ETFE
<b>DNa</b>	40	65	80
<b>DNm</b>	25	40	50
<b>a (mm)</b>	80	80	100
<b>B2</b>	190	190	190
<b>B3</b>	152	152	152
<b>ød</b>	17	17	17
<b>h1</b>	180	180	180
<b>h2</b>	160	160	160
<b>L1</b>	277	277	277
<b>L2</b>	15	15	15
<b>L3</b>	208	208	208
<b>L4</b>	17	17	17
<b>L5</b>	11,5	11,5	11,5

f1	ETN EVO 50 PP / ETFE	ETN EVO 60 PP / ETFE	ETN EVO 70 PP / ETFE
<b>Motor dimensions</b>			
<b>80 (mm)</b>	175.5	175.5	175.5
<b>90 (mm)</b>	175.5	175.5	175.5
<b>100 (mm)</b>	175.5	175.5	175.5
<b>112 (mm)</b>	175.5	175.5	175.5
<b>132 (mm)</b>	193.5	193.5	193.5
<b>Motor shape</b>	<b>B5</b>	<b>B5</b>	<b>B5</b>
<b>Pump weight (without motor)</b>	32	32	37

### Pump dimensions

Model	ETN EVO 50 PP / ETFE	ETN EVO 60 PP / ETFE	ETN EVO 70 PP / ETFE
<b>DNa</b>	40	65	80
<b>DNm</b>	25	40	50
<b>a (mm)</b>	80	80	100
<b>A</b>	96,5	96,5	96,5
<b>B2</b>	338	338	338
<b>B3</b>	304	304	304
<b>ød</b>	14	14	14
<b>h1</b>	235	235	235
<b>h2</b>	160	160	160
<b>L1</b>	650	650	650
<b>L2</b>	80	80	80
<b>L3</b>	440	440	440
<b>L4</b>	80	80	80
<b>L5</b>	6	6	6

### Base dimensions

f1	ETN EVO 50 PP / ETFE	ETN EVO 60 PP / ETFE	ETN EVO 70 PP / ETFE
<b>Motor dimensions</b>			
<b>80 (mm)</b>	175.5	175.5	175.5
<b>90 (mm)</b>	175.5	175.5	175.5
<b>100 (mm)</b>	175.5	175.5	175.5
<b>112 (mm)</b>	175.5	175.5	175.5
<b>132 (mm)</b>	193.5	193.5	193.5
<b>Motor shape</b>	<b>B5</b>	<b>B5</b>	<b>B5</b>
<b>Pump weight (without motor)</b>	60	60	60

\*L1 the dimension is in accordance with the engine installation

\*\*Flange dimensions in compliance with UNI 1092-2 ISO \ 7005-2 PN 16 RF type B - slotted ANSI 150 RF

\*L1 the dimension is in accordance with the engine installation

\*\*Flange dimensions in compliance with UNI 1092-2 ISO \ 7005-2 PN 16 RF type B - slotted ANSI 150 RF





**CDR Pompe**

Via Raffaello Sanzio, 57  
20021 Bollate (MI)  
Tel. +39 02 9901941

[www.cdrpompe.com](http://www.cdrpompe.com)

**Technical characteristics:**

The data and technical characteristics shown in the General Catalogue are not binding. CDR Pompe SRL reserves the right to implement changes without notice. Therefore the data, the size, performance and any other information reported are indicative and not binding. For any technical details you can request the product update form.