

P60 ATEX

Diaphragm pumps

- **Fluid connections:**
1/2" BSP
- **Air connection:**
1/4" BSP
- **Max flow-rate:**
65 lt/min
- **Max air pressure:** 8 bar
- **Max delivery head** 80 m
- **Max Suction Lift Dry:** 5 m
- **Max Suction Lift Wet:** 9,8 m
- **Max Solid passing:** 3,5 mm
- **Noise level:** 72 dB
- **Max Viscosity:**
20.000 cps
- **Displacement per stroke:** 140 CC~

Available versions



PP+CF



PVDF+CF



ALU



SS

PERFORMANCE

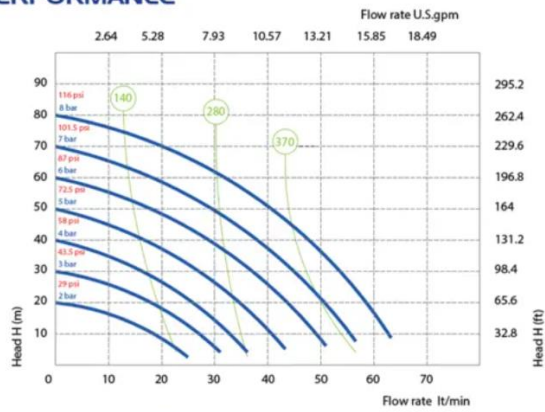

The curves and performance values refer to pumps with submerged suction and a free delivery outlet with water at 20°C, and vary according to the construction material.

DIMENSIONS

	A	B	C	WIGHT	TEMPERATURE	
PP	238 mm	165 mm	249 mm	4 Kg	- 4 °C	+ 65 °C
PVDF	238 mm	165 mm	249 mm	4,5 Kg	- 20 °C	+ 95 °C
ALU	234 mm	165 mm	245 mm	5 Kg	- 20 °C	+ 95 °C
SS	234 mm	165 mm	268 mm	6 Kg	- 20 °C	+ 95 °C

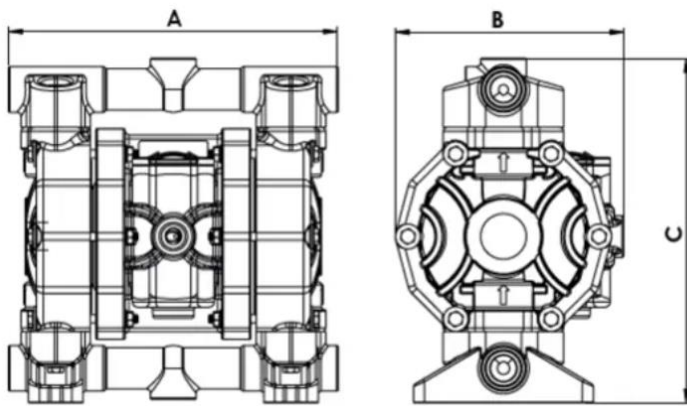

Contact us for more info: info@advantage-eu.com