

P170 - Diaphragm Pump

Diaphragm pumps

- **Fluid connections:** 1" BSP - DN 25
- **Air connection:** 1/2" BSP
- **Max flow-rate:** 170 lt/min
- **Max air pressure:** 8 bar
- **Max delivery head:** 80 m
- **Max Suction Lift Dry:** 5 m
- **Max Suction Lift Wet:** 9,8 m
- **Max Solid passing:** 7,5 mm
- **Noise level:** 75 dB
- **Max Viscosity:** 35.000 cps
- **Displacement per stroke:** 700 CC~

Available versions



PP+VTR



PVDF+CF



ALU (P 160)



SS

PERFORMANCE

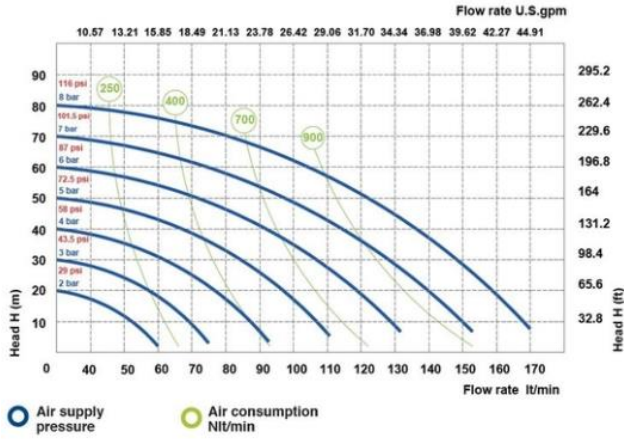

The curves and performance values refer to pumps with submerged suction and a free delivery outlet with water at 20°C, and vary according to the construction material.

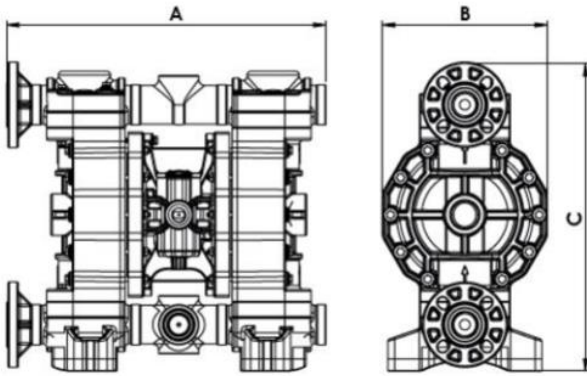

DIMENSIONS

	A	B	C	WIGHT	TEMPERATURE	
PP	430 mm	222 mm	416 mm	15 Kg	- 4 °C	+ 65 °C
PVDF	430 mm	222 mm	416 mm	16 Kg	- 20 °C	+ 95 °C
ALU	370 mm	222 mm	364 mm	15 Kg	- 20 °C	+ 95 °C
SS	357 mm	222 mm	371 mm	20 Kg	- 20 °C	+ 95 °C

COMPOSITION

MODEL	CASING	DIAPHRAGM	BALLS	SEATS	GASKET	CONNECTIONS	ATEX	PORTS
P0170	P = PP	HT = HYTREL+PTFE	T = PTFE	P = PP	D = EPDM	1 = BSP		zone 2 AB = STANDARD
P0160	KC = PVDF+CF	MT = SANTOPRENE+PTFE	S = SS	K = PVDF	V = VITON	2 = FLANGED		
	SS = SS	H = HYTREL	D = EPDM	S = SS	N = NBR	5 = NPT		
	A = ALU	M = SANTOPRENE	N = NBR	Z = PE-UHMWE	T = PTFE			
		D = EPDM		A = ALU				
		N = NBR						

Contact us for more info: info@advantage-eu.com